

Physics Without Causality - Theory and Evidence

Richard Shoup

Boundary Institute, P.O. Box 3580, Los Altos, CA 94024, USA

Abstract. The principle of cause and effect is deeply rooted in human experience, so much so that it is routinely and tacitly assumed throughout science, even by scientists working in areas where time symmetry is theoretically ingrained, as it is in both classical and quantum physics. Experiments are said to cause their results, not the other way around. In this informal paper, we argue that this assumption should be replaced with a more general notion of mutual influence -- bi-directional relations or constraints on joint values of two or more variables. From an analysis based on quantum entropy, it is proposed that quantum measurement is a unitary three-interaction, with no collapse, no fundamental randomness, and no barrier to backward influence.

Experimental results suggesting retrocausality are seen frequently in well-controlled laboratory experiments in parapsychology and elsewhere, especially where a random element is included. Certain common characteristics of these experiments give the appearance of contradicting well-established physical laws, thus providing an opportunity for deeper understanding and important clues that must be addressed by any explanatory theory. We discuss how retrocausal effects and other anomalous phenomena can be explained without major injury to existing physical theory. A modified quantum formalism can give new insights into the nature of quantum measurement, randomness, entanglement, causality, and time.

Keywords: causality, retrocausality, randomness, quantum measurement

PACS: 03.65.Ta, 03.65.Ud, 03.67.-a

INTRODUCTION

“Development of Western science is based on two great achievements: the invention of the formal logical system..., and the discovery of the possibility to find out causal relationships by systematic experiment...” -- Albert Einstein

“Prediction is very difficult, especially about the future.” -- Niels Bohr

Despite the thorough and impressive successes of orthodox quantum mechanics to explain and predict many phenomena, it is a theory that was constructed to match the experimental facts, and not based on a model of physical processes or the deeper nature of reality. After nearly 80 years, quantum theory rests on a set of mathematical ideas that still engender controversy concerning their meaning and foundation even today. Furthermore, the seemingly strange nature of the quantum formalism has brought into question other commonly held principles (read: assumptions) that were once thought inviolate, such as *locality* and *causality*.

In this informal paper, we propose not just a new or different interpretation of quantum theory, but a modest change to the formalism itself. By probing the mathematical assumptions of orthodox quantum mechanics, we hope to 1) clarify and improve the theory and remove some of the controversy and strangeness, and 2) allow explanations of retrocausal and other anomalous phenomena that are in fact observed in some experiments. The primary points of interest are the supposed non-unitarity and randomness of quantum measurement.

It is proposed and argued below that 1) measurement is unitary evolution when properly considered as a three-way interaction, and thus 2) there is no barrier due to measurement to reversibility or backward influence, and further 3) there is no fundamental randomness generated by measurement.

Ultimately, it will be beneficial to give up the deeply held assumption of (unidirectional) cause-and-effect, and rely on the more general notions of *dependence* and *influence*. If relinquishing cause and effect is too unsettling or painful, we can at least think in terms of *bi-directional* cause. We will take both views interchangeably.

Several interpretations of quantum mechanics have a truly bi-directional structure, most notably the Transactional Interpretation (TI) of Cramer [1]. The TI does not rule out retrocausal signaling, and in fact asserts that influence is “a two-way street”, where the future to some degree determines the past as well as vice-versa. However, the TI does include some fundamental randomness in that there may be a stochastic choice made among several potential absorbers for a given emitter transaction.

Recent experiments, both proposed [2,3,4] and conducted [5], focus directly on the issue of retrocausal communication (signaling) in addition to creating correlations in the present as a result of future interactions [6]. It is generally held that true backward signaling (information transfer) would violate the no-cloning theorem, and have other dire consequences for quantum theory. In contrast, a recent paper by Peacock and Hepburn [7] suggests that “proofs” of the impossibility of backwards signaling are tautological and thus of little or no consequence. We do not take a firm position on the question of signaling here, but examine the possibility and consequences of backwards influence and resulting phenomena.

SYMMETRY AND ASYMMETRY

“For us believing physicists, the distinction between past, present and future is only an illusion, even if a stubborn one.” -- Albert Einstein

Symmetry of Physical Laws

In general, the laws of physics, both classical and quantum, are invariant under time reversal.¹ This means that the equations representing these processes are symmetric in time, and thus a solution for $+t$ is also a solution for $-t$.

Despite these strong time symmetries, we routinely assume only forward causality in much of our thinking about the real world, and in nearly all of the experimental

¹ We will ignore here certain weak interactions manifesting only CPT invariance, and a few other special situations.

sciences. Experiments are said to cause their results, not the other way around. Yet, despite our everyday experience, there is a considerable body of both anecdotal and scientific evidence suggesting retrocausal phenomena. And at the same time, the core assumptions of quantum theory that would prevent actualization of time symmetry and backward causal effects remain enigmatic and contentious.

Asymmetry of Quantum Measurement

Quantum dynamics in the orthodox formalism includes two entirely different types of evolution or change -- unitary evolution described by the Schrödinger equation (linear, reversible, lossless), and measurement or projection (nonlinear, irreversible, information losing) by the Born Rule -- the notorious “collapse of the wavefunction”.

From a superposition of two states of a binary variable such as

$$\Psi = \frac{1}{\sqrt{2}}(|\mathbf{0}\rangle + |\mathbf{1}\rangle),$$

one alternative is selected (projected) during measurement according to the implied probability distribution (Fig. 1). This outcome is assumed to be entirely random, causeless, and thus unpredictable. Only statistical statements can be made about the result, in this case an equal distribution of **0** and **1** states. Once the measurement is complete, the resulting state is a classical one, and subsequent measurements of the same variable will also give this result.

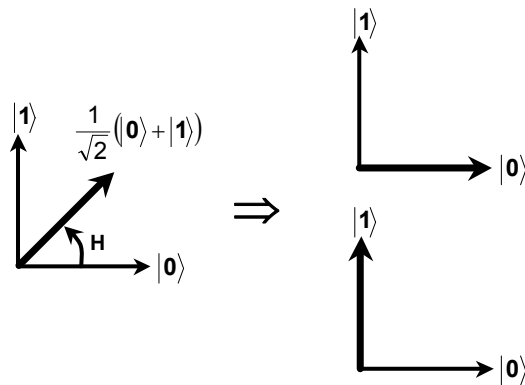

FIGURE 1. Superposition and measurement as vectors in Hilbert space. A particle initially in state **0** is placed in superposition by a unitary transformation (rotation) *H*. Measurement projects the superposed state non-unitarily and unpredictably onto **0** or **1**, according to orthodox theory.

This non-unitarity of the collapse of the wavefunction due to measurement has been the most vexing and controversial aspect of quantum theory from its inception, and yet the theory has been supported by many experimental tests to great precision. A wide variety of interpretations of the quantum formalism have been proposed to mitigate the practical and philosophical difficulties of this part of the theory. There have also been

various attempts to linearize measurement or avoid the irreversibility by other means, for example [8], but these have generally introduced additional assumptions or constraints upon the situation.

A part of the difficulty lies in the seemingly mysterious nature of superposition itself. By the canonical Copenhagen interpretation, the variable in a superposed state has no value at all until it is measured. However, another more basic and useful interpretation of superposition follows directly from the Hilbert space picture (Fig. 1): The superposed state is quite definite and not uncertain at all, it is just not in the laboratory basis. It is a definite vector, but not aligned with our preferred coordinates. In fact, such a superposed state is most often obtained from a classical state by a unitary transformation (i.e. a rotation) such as the Hadamard operator H mentioned above. Since a unitary transformation does not lose information or increase the entropy of the transformed state, the superposed state must still be quite definite.

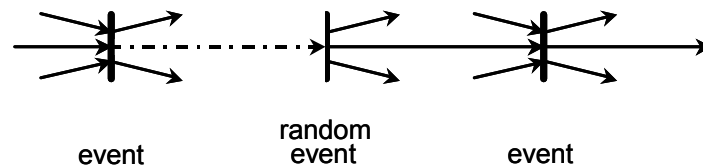

FIGURE 2. A random event breaks the causal chain and prevents potential backwards influence. (Horizontal lines represent variable dependencies that connect events, and time progresses to the right.)

The consequences of the assumed random “collapse” are severe. We will focus here on two of them: 1) the introduction of a fundamentally random element at the core of physical reality; and 2) the prevention of backwards influence or retrocause. While unitary evolutions inherently permit reversed or backward influences to propagate, a random (and thus causeless) event breaks the dependency connection or causal chain and prevents this (Fig. 2). Below we elaborate on this point, and argue that quantum measurement is not a collapse at all, but is best modeled as a unitary three-way interaction that is not random and that does not preclude retrocausation.

QUANTUM ENTROPY AND MEASUREMENT

“You should call it entropy... No one really knows what entropy really is, so in a debate you will always have the advantage.” -- John von Neumann to Claude Shannon

Quantum measurement is traditionally thought of as a two-party interaction between a classical measuring apparatus and the quantum system being measured. However, Cerf and Adami [9,10,11], applying their quantum entropy work to a key observation by Hans Bethe, have explained how quantum measurement should properly be considered as a *three*-way interaction among the measurer (the apparatus), the measuree (the system), and the environment (everything else), with each described

as a fully general quantum system.² From this view, Cerf and Adami show how classical correlations and apparent randomness appear in the usual quantum measurement scenario when the environment is ignored.

Two-Particle Interactions

Briefly, this approach begins with traditional classical Shannon entropy as given by

$$H(A) = -\sum_a p(a) \log_2 p(a),$$

where $p(a)$ is the probability of each possible outcome a . Then quantum (von Neumann) entropy is defined similarly in terms of the density matrix, namely

$$S(A) = -\text{Tr}_A [\rho_A \log_2 \rho_A],$$

where ρ_A is the density matrix and Tr_A is the trace on A. The entropy of a two-particle system in several configurations can be visualized with Venn diagrams as shown in Fig. 3.

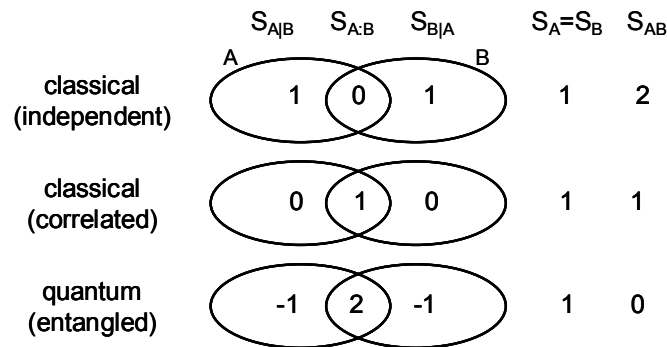

FIGURE 3. Entropy of classically independent, classically correlated, and quantum entangled two-particle configurations (after Cerf and Adami [10]).

At least two aspects of the entangled state are noteworthy here. First, the shared entropy of the entangled state $S_{A:B}$ is *two* bits -- greater than either of the system's parts taken separately. It is for this reason that entanglement is without a classical counterpart, and is sometimes described as “supercorrelation”. These two bits of shared quantum entropy are mapped onto two classical bits in the well-known quantum teleportation and dense coding examples.

Second, the conditional entropies $S_{A|B}$ and $S_{B|A}$ are less than zero.³ A conditional entropy is best thought of not as a quantity, but as a difference between quantities, just as a (potentially negative) integer is necessary to represent differences between natural numbers. $S_{B|A}$ is the uncertainty remaining in B when we have already determined A.

² Three-way measurement interaction and environmental decoherence have also been discussed previously by Zurek [12,13].

³ Negative conditional entropy is related to the concept of Conditional Mutual Information (CMI), see for example Tucci [14].

That is, $S_{B|A} = S_{AB} - S_A = 0 - 1 = -1$. Since this quantity is negative, it means that having determined A there is *less than no uncertainty* or freedom in B. Thus B is in a sense overdetermined by specifying A, and this is the essence of entanglement.

Three-Particle Interaction and Measurement

In the case of three maximally entangled particles (Fig. 4), a similar analysis shows that since the total system entropy $S_{ABC} = 0$, and each of the three elements must itself possess 1 bit of entropy and share 1 bit with each of the other two, then again the conditional entropies such as $S_{A|BC}$ must be negative.

Furthermore, it may be observed that by considering only two components (A and B) and ignoring (tracing over) the third (C), the situation reduces to exactly the classical correlation case of Fig. 3 above. This becomes quite significant when we associate the three entangled elements A, B, and C in a measurement scenario with the measured system, the measuring apparatus, and the environment, respectively. Considering only the measurer and the measuree, a non-unitary collapse to a classical correlation appears, even though *the full three-way interaction is a unitary transformation*. For details and several illustrative examples, see [10].

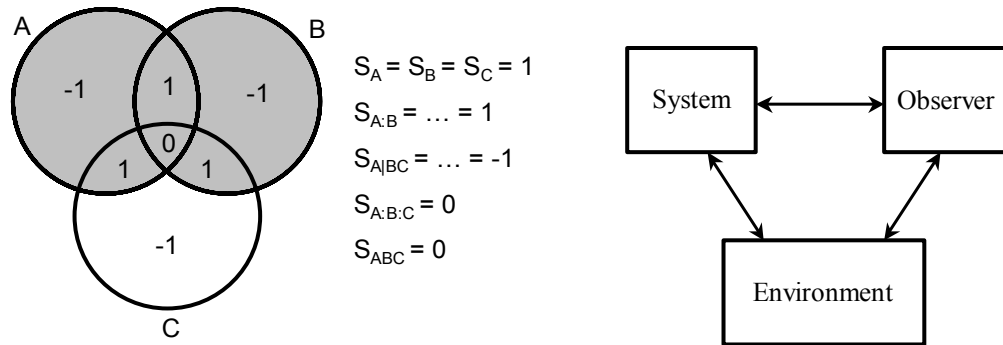

FIGURE 4. Entropy of three entangled particles (after Cerf and Adami [10]). Summing the entropy in areas A and B while ignoring C gives the same 0-1-0 result as classical correlation in the prior figure. Thus the collapse is only apparent, and measurement is actually a unitary three-way interaction.

If the Cerf and Adami viewpoint and analyses are valid, and all dynamics are ultimately unitary, then there are several significant implications, not the least of which are 1) *backward influence is possible across a measurement* and 2) *the apparent randomness introduced by measurement is illusory*. If quantum measurement is unitary, then there is no projection or “collapse” of the wavefunction at all, and thus information is not lost or created, merely moved around. The statistical indeterminacy (randomness) generated by measurement is only apparent, and due to the absence of context. There is no barrier to retrocausality, and the most inelegant, confusing, and contentious part of orthodox quantum theory has been artfully removed.

RANDOMNESS

“The generation of random numbers is too important to be left to chance.” -- Robert R. Coveyou

Randomness can be defined in several ways - statistically, or alternatively in terms of a generating process or device. Statistically, a (sufficiently long) sequence of values is considered random if it contains no regularities or patterns. That is, all values are equiprobable, as are all sequences of values, and the data will tend to a normal distribution.

In the device context, “random” means 1) *uninfluenceable*, that is, causeless (in the usual forward sense), and 2) *unpredictable*, that is, unpatterned. A *true* Random Event (or Number) Generator (REG/RNG, Fig. 5) is a physical process, not an algorithm, and is embodied as a device having one output and no inputs, and no internal memory.

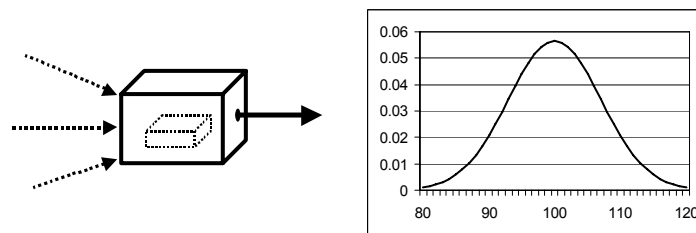

FIGURE 5. True Random Event Generator having no inputs and no internal memory.

Unpredictability simply means a lack of any pattern in a series of outputs from the device. If *no memory* (storage elements) exist in the generator, then an output value cannot be dependent on any previous outputs, and the entropy is therefore exactly $\log_2 n$ bits per output, where n is the number of (equiprobable) output values.

We can think of a truly random uninfluenceable generator schematically as having *no inputs*, no way of affecting it from outside. However, if we wish to control *when* each output is produced, then there must be at least one input -- the “go” signal that induces the generator to output its next value. Alternatively, we can rely on a process such as radioactive decay, where each emission is said to occur at a random time and is not controllable or predictable.

In practice, REGs are typically constructed around an ongoing physically random process such as a radioactive substance or noise in a semiconductor diode, and this process is then sampled (queried) at appropriate times when a value is needed, for example [15]. In the typical zener diode implementation, thermal noise, shot noise, and quantum effects play a part in generating random output values. High quality quantum-random generators have also been devised using optical techniques [16].

Origins of Randomness

Having assumed that physical processes such as these can indeed produce statistically random streams of **0/1** bits, for example, that are not predictable nor influenceable, there remains the pertinent and persistent question: Why is a given

output **0** or **1**? If we obtain a **0** value from the generator, why is it **0** this time and **1** another time? After all, one bit of information has been provided by each sample, so where did that information come from? Similarly, why is a particular sequence of random values as it is, and not some other equally random sequence? If God does indeed play dice, as Bohr famously argued to Einstein, then does He reach down and provide each output bit from every REG whenever required?

The hypothesis of backward influence or retrocausal discussed above suggests that the answers to these questions lie in the future dependencies of the REG. The output of an REG is (by construction as well as in principle) not biased toward any value at any time, nor is it biased towards any sequence of values. Such a generator is designed specifically to exert no bias or influence whatsoever on the values that emanate from it. Therefore there seems to be only one other possible source for determining its values (ignoring divine intervention): *These output values must be determined via backwards influence from dependencies of the generator* -- the devices or circuits or devices to which the generator is connected. Perhaps a REG is best thought of as an *empty box*, and its output as an *input*, free to be directed retrocausally by those elements to which it is connected -- the measuring device and environment. We have explored this idea somewhat further below and in a previous paper [17].

Following this line of reasoning, then, the output values of such a generator in typical macroscopic experiments will usually *appear completely random simply because there are a great many dependents*. Typical experiments necessarily include one or more amplification events involving a large number of particles as dependencies of a quantum variable or event in order to make it observable. These particles are typically at laboratory temperature, and thus their uncoordinated actions will appear entirely random when reflected back to the REG's "output".

CAUSALITY

"The law of causality, I believe, is a relic of bygone age, surviving, like the monarchy, only because it is erroneously supposed to do no harm." -- Bertrand Russell

The laws of physics are largely or entirely time symmetric, yet in the macroscopic domain we observe strong thermodynamic and psychological arrows of time. The 2nd Law of Thermodynamics holds that in an isolated system entropy will tend to increase over time. This progress towards disorder is generally thought of as simply a consequence of the greater probability of greater numbers of disordered states. According to cosmological theory, the universe has been cooling (increasing in entropy) since the beginning (the Big Bang), and the resulting local entropy gradients (the Sun-Earth system, biochemical reactions, and so on) give rise to the thermodynamic and psychological arrows of time. These arrows of time point in a single direction, and thus seem contrary to the possibility of retrocausal influence.

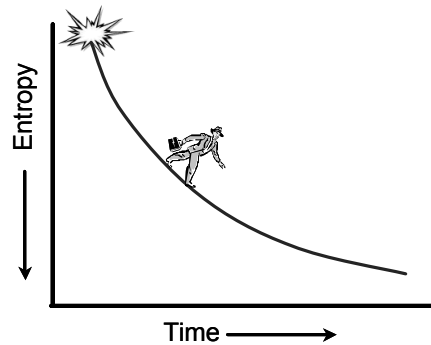

FIGURE 6. According to theory, entropy has been continually increasing since the Big Bang, thus indirectly giving rise to the thermodynamic arrow of time.

The Arrow of Time and Retrocausal Influence

In daily life, we routinely observe forward causal influence, in both macroscopic and microscopic systems. If all quantum dynamics are indeed time-symmetrical and unitary, as has been argued here, then why aren't there a lot of retrocausal effects?

Our answer: There are! But they are small and often quite subtle. The evidence is abundant in carefully controlled laboratory experiments in parapsychology and elsewhere (see below). These effects are small and elusive, it is suggested, because we stand on a steep statistical slope (Fig. 6), where influence on the future (downhill) is easy, and influence on the past (uphill) is much more difficult. The low entropy of the past (presumably leading back to the Big Bang) gives the universe a strong arrow of time. We are therefore much more likely to observe evolution of a system in the forward direction than the reverse. As aptly noted and discussed at length by Price [18], the important question may not be why entropy is continually increasing (in accordance with the 2nd law, etc.), but why entropy was so low in the past.

In special circumstances such as with only a few isolated particles, it is not too difficult to observe time symmetry in physical interactions. However, to see macroscopic retrocausal effects typically would require manipulation or influence on a large number of particles. Since small effects are in fact sometimes seen in controlled experiments, more research is clearly called for.

It is well known that some people seem to be particularly adept at "psychic" tasks and often demonstrate anomalous abilities of the sort discussed here, see [19,20,21] and below. *It may be that persons who frequently experience these anomalous phenomena have the ability to themselves act like REGs -- to reduce their own determinism and increase the mutability of their mental choices to such a level that they are responsive to subtle backward influences.* This hypothesis is consistent with a variety of experimental data showing correlation between psi performance and meditation, and other spiritual practices directed at quieting the mind [19].

precognition, and psychokinesis (collectively known as “psi” phenomena) have been observed repeatedly in carefully controlled laboratory experiments by numerous experimenters over decades. Unfortunately, a great deal of nonsense surrounding “paranormal” experiences in the general culture has tended to obscure and drown out this important scientific research.

In the author’s opinion, there is highly credible evidence for these phenomena, with obvious significant implications, and these data should be seriously considered by every forward-looking physicist interested in a deeper understanding of reality. Excellent introductions to this body of research may be found in books by Radin [19,20] and others, and in peer-reviewed journals such as the Journal of the Parapsychological Association [25] (notably an AAAS affiliated society since 1969), the Journal of the American Society for Psychical Research [26], and others.

Until recently, most physicists have assumed -- largely without examination -- that these data cannot be taken seriously because they *appear* to violate well-confirmed and accepted physical laws, and especially offend our notion (assumption) about cause and effect. In fact, it has been believed and asserted by many scientists that a complete rewrite of physics would be necessary if these phenomena are real. But as we have suggested above, this is simply not so, and only modest changes in the foundations of quantum theory are needed to allow and to explain many of the phenomena that have been observed in parapsychology experiments for many years.

Characteristics of the Phenomena

From the significant body of experimental evidence, a few important properties of these anomalous psi phenomena have emerged. We list a few of them here for interest, for reference later, but without thorough discussion.

1. Time/order independence (clairvoyance vs. precognition) - Evidence suggests that a target can be chosen before or after the subject’s response with equal success.
2. Complexity independence (goal orientation) - Evidence suggests that the complexity of the task doesn’t matter, only the desired outcome.
3. Selectivity - Evidence suggests that a subject can “tune in” to a particular target.
4. Experimenter effect (belief, audience) - Evidence suggests that some experimenters routinely obtain significant psi effects, while others do not, even with the same experimental protocol.
5. Small effect, unavailable to evolution - Evidence suggests that while the survival value of even a little psi ability would be quite high, evolution has not selected for it and produced much more in living systems.

Perhaps the most shocking and problematic -- and thus the most pregnant -- characteristic of psi phenomena listed is their *apparent independence of time order* (#1 above). Experimentally, for example, it does not seem to matter much whether a remote viewing takes place before, during, or after the viewed event [19]. Persistent

evidence suggests strongly that thinking about these phenomena in terms of the usual notions of cause and effect is likely to be counterproductive -- and may in fact be *the* major impediment to a deeper understanding.

With the stakes as high as causality, randomness, and time, it is difficult to overstate the importance of research into these phenomena. Progress in this area may well lead to a reformulation and re-interpretation of quantum theory, as suggested above, and thus to deep reconsideration of some parts of physics. Even the scientific method itself, based largely on a concept of limited causality and forward influence, may be in need of re-examination. However, it does appear that a major rewriting of physics is not indicated or necessary, and would be highly implausible in any case.

Some Experiments Interpreted

The experimental evidence supporting the above retrocausal hypothesis is perhaps far from conclusive, but it is already substantial and growing, if proper interpretations are given to results already returned. Evidence considered here is of two kinds:

1. Perturbations of supposedly random processes, thus contradicting the assumption of fundamental randomness at the core of quantum mechanics, and
2. Experiments showing actual retrocausal influence, i.e. the future influencing the past such as in precognition.

Several examples of both types are presented elsewhere in this volume [27,28,29], and so will not be repeated here. While a thorough review of psi experiments is not possible here, we give two brief examples chosen for their particular relevance.

Perturbations of Random Processes - Evidence Suggesting Mutability

A network of random number generators (RNGs) has been developed by the Global Consciousness Project (GCP) and has been in continuous operation since 1998 [30]. Approximately 70 generators exist today scattered around the globe, each sending 200 random bits per second back to a central server for storage and later analysis. Analysis methods and all generator data are available on the GCP website [30]. According to the GCP, at times behavior of the network seems to deviate significantly from chance, especially around times of notable human events.

In particular, highly unusual behavior was seen on and around the tragic day of September 11, 2001. This behavior has been discussed in detail by Nelson et al [31], and in this volume [29], so we present here only one particular view of the data not given elsewhere, see Fig. 8.

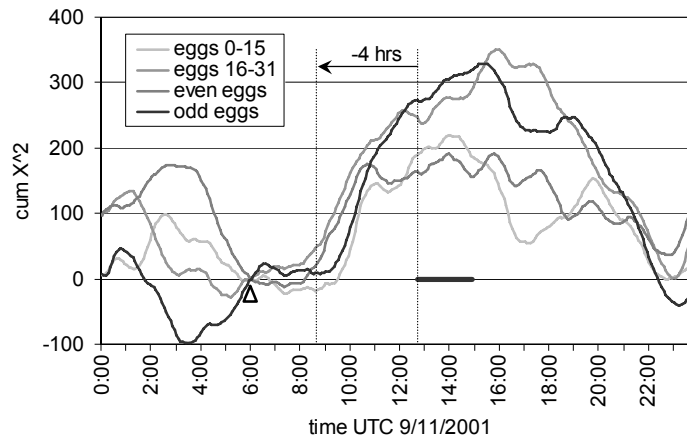

FIGURE 8. Correlations among random generators (EGGs) on September 11, 2001, in several groupings. Deviations beginning 4 hours prior to the events of that day (horizontal bar) suggest retrocausal influence, and thus no prosaic explanation.

On this date, over 30 random generators (here called “EGGs”) were operational. No significant disruption of data was observed during or after the events of that day, and no data was lost during this period. The figure shows the standard cumulative χ^2 statistic for several groupings of 32 generators for the full day. Data have been fixed (pinned to zero) at 0600 hours because this begins a period of relative quiescence for all four curves, and significantly precedes the key events of the day.

Beginning approximately four hours before the events, variance of the generators dramatically increased. (Four different groupings are shown to emphasize that significant deviations were seen simultaneously across most if not all the generators, not just a few.) The disturbance continues for more than eight hours, gradually subsiding later in the day. No deviation of this magnitude has been seen anywhere in the eight-year database collected from the generator network. Note that the four-hour offset rules out any possible prosaic explanations such as electromagnetic or other influence on the generators due to unusual human activity following the tragic events.⁴

It is difficult to interpret this behavior of many supposedly random devices, but evidence has been presented for correlations with global human events [31]. For our purpose here, we simply emphasize that 1) these devices deviated significantly from expected chance behavior during this period, and 2) that the deviations occurred well prior to the events with which they were presumably associated. Therefore we take this behavior as (anecdotal, not formal) evidence of mutability in supposedly random uninfluenceable processes, and of retrocausal influence upon them.

⁴ It is also noteworthy that this network is not a parapsychology experiment, with subjects trying to intentionally influence the generators or guess random targets. The generators operate entirely autonomously, and are not generally the focus of any human thought processes (except perhaps those of the network researchers).

Experiments Involving Anomalous Correlations

Consider a simple guessing game of the form shown in Fig. 9. The subject tries to make his guess (symbol S) match a target generator (symbol T), and the results are tallied (R).

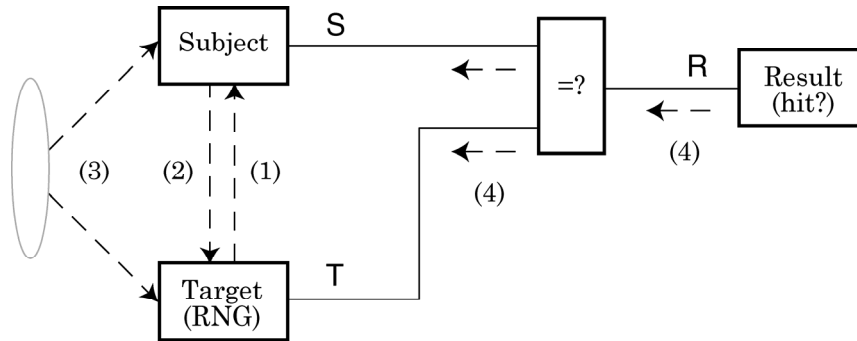

FIGURE 9. Possible paths to bring about extra-chance correlation between subject and Target.

Suppose an experiment of this type has been conducted, and the results show a hit rate higher than that expected by chance, as in many published examples [25,26]. We assume that all forms of ordinary signaling or leakage between subject and the target generator have been prevented, and ask how this physical anomaly could be explained [32,33,34,35]. Consider four general possibilities as highlighted in the figure:

1. Influence from T to S in the Present. The subject was somehow able to sense the target bits and adjust his guesses accordingly. This is the standard explanation involving clairvoyance (S chosen after T) or precognition (S chosen before T). The associated mechanism would have to include a previously undetected means of information transfer utilizing an undiscovered human sensitivity or sense organ. This doesn't seem very plausible, yet it is still a commonly assumed hypothesis about how these phenomena must work. Moreover, if the target is chosen after the guess, then the subject must possess some precognitive ability, and this would require information flow backwards in time, contrary to the "law" of cause and effect.

2. Influence from S to T in the Present. The subject was somehow able to affect the target generator directly. This is the usual psychokinetic explanation, difficult to accept, yet apparently supported by many careful real-world experiments, for example [36,37]. Quantum processes that are now considered to be fundamentally random would have to be influenceable, and information conveyed in some currently unknown way. A new or unnoticed force or field would seem to be necessary -- unlikely in the face of existing and well-tested physical theory.

3. Influence via the Past. The subject was somehow able to make use of prior correlations or entanglement between himself and the target generator to make or adjust his guesses, similarly to (1) above but conditioned by past *common cause*. After all, real RNGs have a physical history, and their performance may not be entirely

isolated from the past, as is usually assumed. According to cosmological theory, all matter has interacted in the past, even if quite remotely. It is generally assumed that any residual correlations between well-separated objects has long ago been erased by unavoidable decoherence at ordinary temperatures, but this seems far from conclusively established. While this hypothesis might explain clairvoyant or precognitive effects, some way to affect quantum random sequences would still be required in order to explain psychokinesis of the sort seen in laboratory experiments.

4. Influence via the Future. Anomalous results in the future were reflected backwards through the equality constraint to affect the target generator by common cause (similarly to hypothesis 3 above, but relying on a future interaction). It is this hypothesis in which we are most interested.

With hypotheses 1 and 2, an additional unknown path of influence or information flow would be necessary between S and T, and this seems to be in serious conflict with well-established physical theory. However, *alternatives 3 and 4 do not require any direct or indirect information transfer between S and T*, instead relying on correlation, and thus do not imply such a mysterious path nor the difficulties associated it.

In particular, hypothesis 4 (correlation due to future interactions) can readily account for many if not all of the so-called clairvoyant, precognitive, and psychokinetic anomalistic effects apparently exhibited in such experiments, and is in good agreement the psi characteristics listed above as well, without requiring new paths or mechanism or any major insult to well-accepted physical law -- if we allow symmetrical (bi-directional) causal influence as argued above.

It may be emphasized that “common cause” correlations may be seen in the present as a result of interactions in the past or in the future (see above). The former are easy to see, and agree with our common sense everyday experience, while the latter are more difficult and enigmatic. Our hypothesis considers these as entirely equivalent and symmetrical possibilities, except for the much smaller likelihood of the latter due to naturally increasing entropy. See also Price [18] on this subject.

Precognition - Evidence Suggesting Retrocausality

A simple experiment of the type described above has been running on our public “GotPsi?” web site [38] since August 2000, and as of August 2006 has recorded over 20 million trials, currently logging about 20,000 per day. Details of the “Card Test” and several other experiments on the web site and some early results can be found in a report by Radin [39], who originated the tests.

In the on-line Card Test, the subject is asked to guess which of five playing cards has a picture “on the other side”, see Fig. 10. The result of each one-in-five forced choice trial is shown to the user, and runs of 5, 10, or 25 trials are tallied and odds displayed.

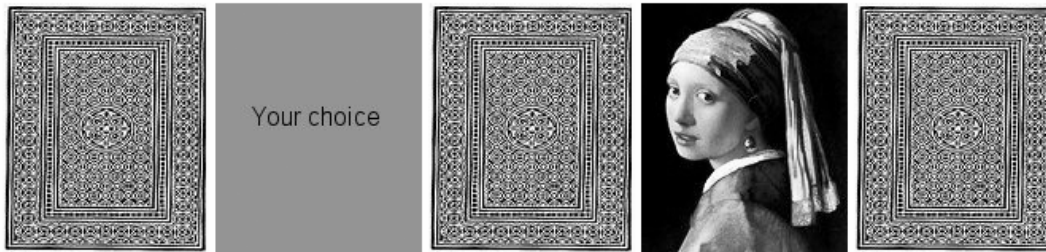

Sorry, that was a miss -- 1 hits in 3 trials, hit rate = 33%

FIGURE 10. One completed trial in the on-line Card Test.

Figure 11 shows the daily hit rate for all subjects (typically 100-200 each day) over two years of operation of this experiment, filtered with a sliding average window of 30 days, and normalized as a z score. Generally, the hit rate z score moves randomly within a range of about $z = \pm 2$, ($p > 0.02$).

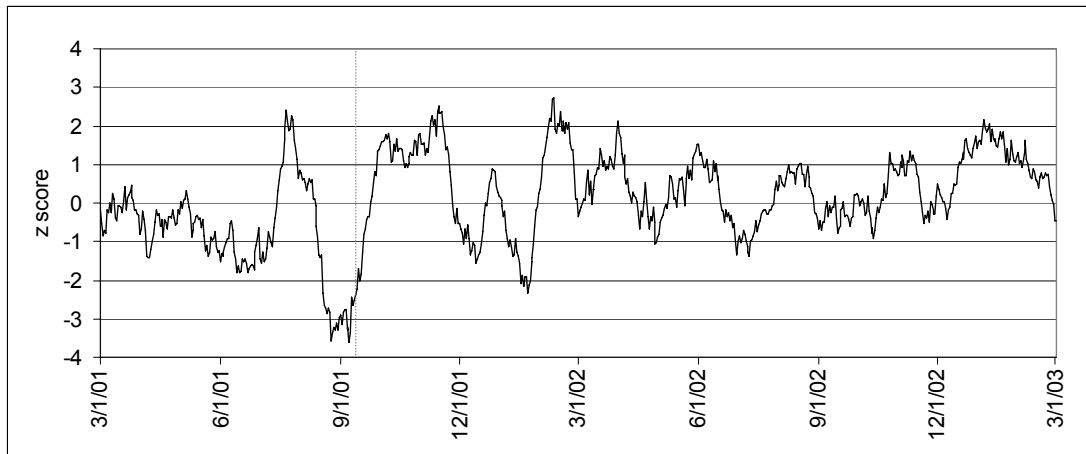

FIGURE 11. Card Test normalized daily hit rate for all subjects from March 2001 to March 2003. The dashed line indicates September 11, 2001, the end of a highly unusual period of negative scoring.

The daily hit rate appears to behave statistically as expected except for the striking peak and deep notch beginning in July and ending in early September of 2001. For unknown reasons, the hit rate rose above $z = 2$ (max $z = 2.4$, $p = 0.0082$) and then fell dramatically during the period just prior to September 11, 2001, staying below $z = -3$ (min $z = -3.6$, $p = 0.00016$) for over two weeks. (This drop of greater than 5 standard deviations is itself highly unlikely, as is the lengthy low period, no less given their timing.) Then almost immediately after September 11, the hit rate rose steeply again, and returned to ostensibly random behavior, which continues to this day. Although such performance by subjects is possible by chance alone, the probability is quite low, and nowhere else in the entire six-year database of the Card Test is any similar excursion found.

Apparently, a few weeks before September 11, subjects participating in the Card Test suddenly became quite poor at guessing cards, selecting incorrect cards far more often than chance would suggest.⁵ Remarkably, almost immediately following that key date, performance vastly improved for a period and then returned to varying randomly in accordance with expected probabilities. If it is inferred that results during this highly unusual period are somehow related to the tragic events of September 11, 2001, then they are precognitive by several weeks, and therefore constitute *prima facie* evidence for retrocausal influence of those events on this experimental task.

Both significant extra-chance hitting and missing constitute evidence for non-zero correlation between subject and target, and thus some coordinating influence must have been acting between them. Since there is no known information channel connecting them directly, and no plausible common influence in the past, it is suggested that this anomalous correlation is mediated by the only remaining path -- their interaction in the future result comparison, as discussed above. This interaction could presumably produce such correlations whether S is chosen prior to or after T, and we examine these two cases separately below.

Time/Order Independence - Offset Targets

Target generation in the Card Test is actually done in a way that allows further testing of the hypothesis of time independence of these anomalous effects. Unknown to the subject, several different types of target generation can be employed on a trial-by-trial basis. For each trial, *two* target cards are potentially generated, as shown in Fig. 12, one prior to the subject's guess (T1) and one afterwards (T2). An ancillary random choice determines which method is used, and thus which of the two targets will actually be compared with the subject's guess.

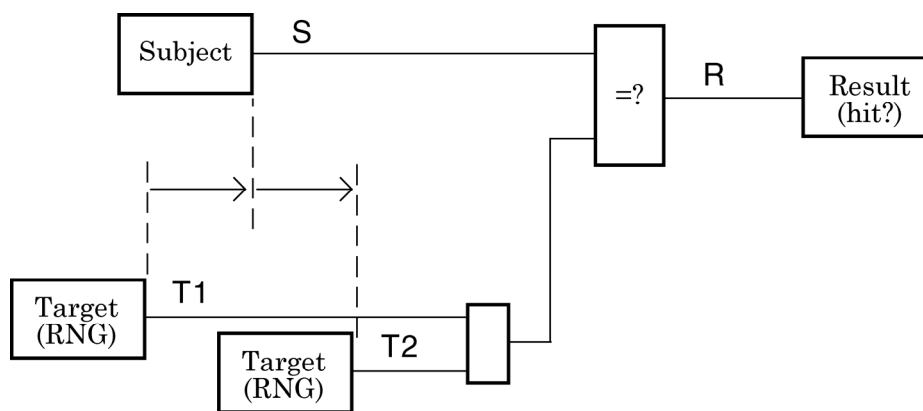

FIGURE 12. Card Test experiment with target T1 chosen before, and T2 after, the subject's guess.

⁵ It should also be noted that examination of the T1 and T2 target distributions during this period shows no significant departure from chance expectations.

Figure 13 shows the daily hit rates separately for those trials using the T1 (prior) target and those using the T2 (later) target.

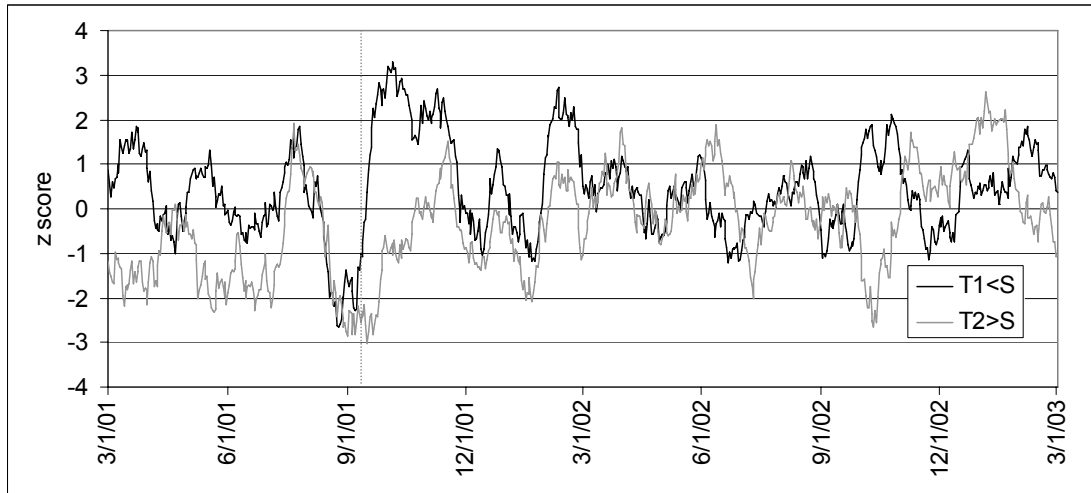

FIGURE 13. Normalized Card Test hit rate for targets T1 (before the subject's guess) and T2 (afterwards). Note the unusual behavior of the two curves surrounding 9/11 (dashed line).

As with the combined daily hit rate shown previously, each of these curves represents the success rate for the subject's guess matching a randomly generated target. By the null hypothesis (chance behavior), these curves should represent two *independent* random walks -- as they seem to prior to mid-2001, and after mid-2002.

Contrary to the expected behavior, beginning in July 2001 the two hit rates behave remarkably similarly and non-randomly for most of a year. They rise together to a peak near $z = 2$ in mid-July, then fall closely together to a low below $z = -3$ through the beginning of September. Then shortly after September 11, the T1 (prior) hit rate rises dramatically while the T2 (post) hit rate remains low for several more weeks and rises more gradually. The curves appear to rejoin in November, track each other closely again throughout the first six months of 2002, and then begin to diverge and revert to the expected independent random walks (which continue to the present).

A thorough *post hoc* analysis of this strange non-random, non-independent behavior of the on-line Card Test hit rates is beyond the scope of this informal paper, and here we will allow the visual impact of the curves to suffice. These data show evidence of anomalous correlation of the subject's guess with the targets chosen both before and after the fact. The data appear to show evidence for precognition as well, and thus retrocausation, since the T2 targets were not generated by the RNG until after the subject's guess had been made and recorded.

In addition, anomalous correlations are apparent between the T1 and T2 hit rates, and show variation relating to the special date of September 11, 2001. During the period before and after 9/11, hit rates for prior and post targets behaved remarkably similarly and anomalously, suggesting that a common mechanism was operating in both conditions. This apparent independence of temporal order is in agreement with

that seen in many other experiments in the parapsychology literature, for example [40,41].

But interestingly, there is also a clear (but temporary) distinction between the two conditions for a period of about two months just after 9/11, suggesting that the time offset was somehow discernible to the subjects or affecting the targets during this period. Further study is certainly indicated.

SUMMARY AND COMMENT

"If you haven't found something strange during the day it hasn't been much of a day."
-- John A. Wheeler

We have argued here for retrocausal influence as a natural consequence of time-reversal invariant physical processes, including unitary quantum measurement. It is suggested that the traditional idea of cause and effect should be retired, and replaced with a more general notion of bi-directional influence. In so doing, the formalism of quantum mechanics may be modified such that all evolution, including measurement, is unitary and thus reversible, and there is no fundamental randomness at its core.

Experimental evidence, presented informally here, supports this hypothesis in outcome as well as in general characteristics. For poorly understood reasons, a particular period of time seems to have been associated with highly unusual behavior in an autonomous network of random devices, and also with highly anomalous performance by many human subjects in an on-line forced-choice card guessing experiment. Both theory and evidence suggest that assumed random processes are in fact mutable, and that retrocausal effects such as precognition do happen.

It is generally assumed that physical random processes such as true Random Event Generators produce definite values in a completely non-causal way, and thus represent the gold standard for independence in experimental sciences. In contrast and ironically, according to the present theory a true REG appears instead to be the least definite, most malleable device possible. Having no bias whatsoever of its own, by design, it is completely subservient to incoming influences from its future dependencies, the very clients it purports to serve.

While the theory presented above shows promise, it should be clear that we have just scratched the surface of understanding and interpreting it, particularly in the experimental explorations performed thus far in this area. The potential implications for science and society of a deeper understanding of causality, randomness, and time are quite broad and consequential, and thus further research is strongly indicated.

ACKNOWLEDGMENTS

The author wishes to thank numerous colleagues including Daniel Sheehan, Dean Radin, Henry Stapp, Nick Herbert, and John Cramer for helpful comments and stimulating discussions on these topics.

REFERENCES

1. J. G. Cramer, *Reviews of Modern Physics* 58, 647-687 (1986); www.npl.washington.edu/TI.
2. J. G. Cramer, "Reverse Causation and the Transactional Interpretation of Quantum Mechanics", in *Frontiers of Time: Retrocausation -- Experiment and Theory*, D. P. Sheehan editor, *AIP Conference Proceedings for 87th Meeting of AAAS Pacific Division*, University of San Diego, 2006 (this volume).
3. R. Srikanth, "An extended Einstein-Podolsky-Rosen thought-experiment", 2001, quant-ph/0101022 v2.
4. R. Srikanth, "Do quantum nonlocal correlations imply information transfer? - A simple quantum optical test", 2001, quant-ph/0101023.
5. B. Dopfer, *Two Experiments with Two-Photon Interference*, PhD Thesis (in German), U. Innsbruck, 1998.
6. A. C. Elitzur, S. Dolev, and A. Zeilinger, "Time-Reversed EPR and the Choice of Histories in Quantum Mechanics", *Quantum Computers and Computing*, 2002; and in the *Proceedings of XXII Solvay Conference in Physics*, New York, World Scientific, 2002; quant-ph/0205182.
7. K. A. Peacock and B. Hepburn, *Proc. Meeting of the Society of Exact Philosophy*, 1999, quant-ph/9906036.
8. Y. Aharonov, P. G. Bergmann, and J. L. Lebowitz, "Time Symmetry in the Quantum Process of Measurement", *Phys. Rev.* 134, B1410-B1416, 1964.
9. C. Adami, and N. J. Cerf, "Negative entropy and information in quantum mechanics", 1995, quant-ph/9512022.
10. N. J. Cerf, and C. Adami, "Quantum Mechanics of Measurement", 1996, quant-ph/9605002 v2.
11. N. J. Cerf, and C. Adami, "What Information Theory Can Tell Us About Quantum Reality", 1998, quant-ph/9806047.
12. W. H. Zurek, "Pointer basis of quantum apparatus: Into what mixture does the wave packet collapse?", *Phys. Rev. D* 24, 1516 (1981).
13. P. Zhang, X. F. Liu, C. P. Sun, "An quantum approach of measurement based on the Zurek's triple model", 2002, quant-ph/0204121.
14. R. R. Tucci, "Quantum Entanglement and Conditional Information Transmission", 1999, quant-ph/9909041.
15. Comscire Corp., "Design Principles and Testing of the QNG Model J1000KU", white paper, 2003, www.comscire.com.
16. id Quantique Corp., "Quantis Quantum Random Number Generator", white paper, 2004, www.idquantique.com.
17. R. Shoup, "Anomalies and Constraints", *J. Scientific Exploration*, 16, 1 (2002), also at www.boundary.org/causality.htm.
18. H. Price, *Time's Arrow and Archimedes Point*, Oxford University Press, 1996.
19. D. I. Radin, *The Conscious Universe*, HarperEdge, 1997.
20. D. I. Radin, *Entangled Minds*, Paraview, 2006.
21. D. I. Radin, "Preliminary Analysis of a Suite of Informal Web-Based psi Experiments", 2002.
22. L. H. Kauffman, "Complex Numbers and Algebraic Logic", *Proc. 10th Intl. Symp. Multivalued Logic*, IEEE, 1980.
23. R. Shoup, "A Complex Logic for Computation with Simple Interpretations for Physics", *PhysComp'92, Workshop on Physics and Computation*, IEEE Press, 1993; www.rgshoup.com/prof/pubs.
24. R. Shoup, "Simple Logic for Computation - Why Paradoxes are Unavoidable and Useful", *Paracon'97 Conference on Paraconsistency*, 1997; www.rgshoup.com/prof/pubs.
25. Parapsychological Association, see www.parapsych.org.
26. American Society for Psychical Research, see www.aspr.com.
27. D. J. Bierman, "Empirical research on the radical subjective solution of the measurement problem. Does time get its direction through conscious observation?", in *Frontiers of Time* (ibid, this volume).
28. D. I. Radin, "Psychophysiological and perceptual tests of possible retrocausal effects in humans", in *Frontiers of Time* (ibid, this volume).
29. R. Nelson, "Anomalous anticipatory responses in networked random data", in *Frontiers of Time* (ibid, this volume).
30. Global Consciousness Project, <http://noosphere.princeton.edu>.
31. R. D. Nelson, D. I. Radin, R. Shoup, and P. A. Bancel, "Correlations of Continuous Random Data with Major World Events", *Foundations of Physics Letters*, 15, 6 (2002), see www.boundary.org/randomness.htm.
32. T. Etter, "On The Occurrence of Some Familiar Processes Reversed in Time", 1960, www.boundary.org/causality.htm.
33. T. Etter and H. P. Noyes, "Process, System, Causality, and Quantum Mechanics: A Psychoanalysis of Animal Faith", *Stanford Linear Accelerator Center Publication* 7890, 1998; revised in *Physics Essays*, 12, 4, Dec. 1999.
34. H. Schmidt, "Toward a Mathematical Theory of Psi", *J. American Society for Psychical Research*, 69 (4), 1975.

35. H. Schmidt, "Can an Effect Precede Its Cause? A Model of a Noncausal World", *Foundations of Physics*, 8 (5/6), 1978; also at www.fourmilab.ch/rpkp.
36. H. Schmidt, Helmut, "Observation of a Psychokinetic Effect Under Highly Controlled Conditions", *J. Parapsychology*, 57 (1993), also at www.fourmilab.ch/rpkp.
37. R. G. Jahn and B. J. Dunne, "The PEAR Proposition", *J. Scientific Exploration*, 19, 2 (2005), pp. 195-246; also at www.princeton.edu/~pear.
38. www.boundarylab.org, also known as www.gotpsi.org.
39. D. I. Radin, "Preliminary Analysis of a Suite of Informal Web-Based Psi Experiments", 2002, www.boundary.org/experimental.htm.
40. D. J. Bierman and D. I. Radin, "Anomalous unconscious emotional responses: Evidence for a reversal of the arrow of time", in *Tuscon III: Towards a Science of Consciousness*, MIT Press, 1998.
41. D. I. Radin, "Unconscious perception of future emotions: An experiment in presentiment", *J. Scientific Exploration*, 11 (2), 1997.